

# TXG50c Facts and Data

## Digital Color Matrix Camera, 5.0 Megapixels, Gigabit Ethernet

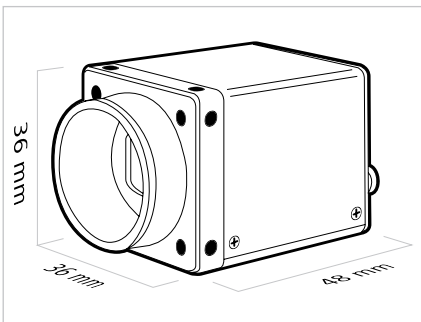

Baumer Optronic GmbH  
 Badstrasse 30  
 DE-01454 Radeberg, Germany  
 Phone +49 (0)3528 4386 0  
 Fax +49 (0)3528 4386 86  
 sales@baumeroptronic.com  
 www.baumer.com/cameras

### Sensor Information

Model Name	SONY® ICX625
Type	2/3" interline progressive scan CCD
Native Resolution	2448 × 2050 pixels
Exposure Time	4 µsec ... 2 sec
Color Filter	RGB Bayer Mosaic

### Acquisition Formats

Image Formats	Full Frame HQ Full Frame	2448 × 2050 pixels 2448 × 2050 pixels	max. max.	7.5 fps 15.0 fps
Pixel Formats <sup>1)</sup>	Mono8, BayerRG8 (BayerRG12, RGB8 Packed, BGR8 Packed, YUV411 Packed, YUV422 Packed, YUV444 Packed)*			
Partial Scan	True Partial Scan, Region of Interest (ROI) arbitrary			

### Image Pre-processing

Analog Controls	Gain (0 ... 20 dB), Offset (0 ... 1023 LSB   14 bit)
Color Models	RGB (YUV, Mono)*
Color Processing	Integrated color processor for high quality color calculation
Color Adjustment	One Push White Balance, User-specific color adjustment

### Camera Features

Internal Buffer	32 MBytes (max. 1 images)
Synchronization	Free running, Trigger
Trigger Sources	Hardware, Software, ActionCommand
Trigger Delay	0 ... 2 sec, Tracking and buffering of up to 512 trigger signals
Digital I/Os	1 input line (with Debouncer), 1 output line

### Interfaces and Connectors

Data Interface	Gigabit Ethernet, Transfer rate 1000 Mbits/sec Connector: 8P8C Modular Jack (RJ45), screw lock type
Process Interface	M8 / 4 pins
Power Interface	M8 / 3 pins

### Mechanical Data

Housing	Aluminum, IP40
Lens Mount	C-Mount
Dimensions	36 × 36 × 48 mm
Weight	< 90 g

### Electrical Data

Power Supply	8 ... 30 V DC
Power Consumption	approx. 6 Watts

### Environmental Data

Operating Temperature	+5 °C ... +50 °C (+41 °F ... +121 °F)
Humidity	10% ... 90% non condensing

<sup>1)</sup> Depending on the adjusted Image Format  
 \* on request