

TXG03c

Facts and Data

Digital Color Matrix Camera, 0.3 Megapixels, Gigabit Ethernet

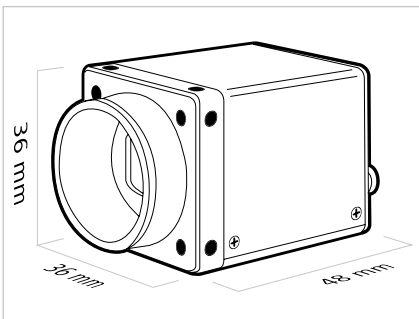

GIG
VISION
GEN<i>i>CAM



Baumer Optronic GmbH
Badstrasse 30
DE-01454 Radeberg, Germany
Phone +49 (0)3528 4386 0
Fax +49 (0)3528 4386 86
sales@baumeroptronic.com
www.baumer.com/cameras

Sensor Information

Model Name	SONY® ICX424
Type	1/3" interline progressive scan CCD
Native Resolution	656 × 490 pixels
Exposure Time	4 µsec ... 60 sec
Color Filter	RGB Bayer Mosaic

Acquisition Formats

Image Formats	Full Frame HQ Full Frame	656 × 490 pixels 656 × 490 pixels	max. 46.0 fps max. 90.0 fps
Pixel Formats ¹⁾	Mono8, BayerRG8, BayerRG12, RGB8 Packed, BGR8 Packed, YUV411 Packed, YUV422 Packed, YUV444 Packed		
Partial Scan	True Partial Scan, Region of Interest (ROI) arbitrary		

Image Pre-processing

Analog Controls	Gain (0 ... 20 dB), Offset (0 ... 255 LSB 12 bit)
Color Models	RGB, YUV, Mono
Color Processing	Integrated color processor for high quality color calculation
Color Adjustment	One Push White Balance, User-specific color adjustment

Camera Features

Internal Buffer	32 MBytes (max. 31 images)
Synchronization	Free running, Trigger
Trigger Sources	Hardware, Software, ActionCommand
Trigger Delay	0 ... 2 sec, Tracking and buffering of up to 512 trigger signals
Digital I/Os	1 input line (with Debouncer), 1 output line

Interfaces and Connectors

Data Interface	Gigabit Ethernet, Transfer rate 1000 Mbits/sec Connector: 8P8C Modular Jack (RJ45), screw lock type
Process Interface	M8 / 4 pins
Power Interface	M8 / 3 pins

Mechanical Data

Housing	Aluminum, IP40
Lens Mount	C-Mount
Dimensions	36 × 36 × 48 mm
Weight	< 90 g

Electrical Data

Power Supply	8 ... 30 V DC
Power Consumption	approx. 3.5 Watts

Environmental Data

Operating Temperature	+5 °C ... +50 °C (+41 °F ... +121 °F)
Humidity	10% ... 90% non condensing

¹⁾ Depending on the adjusted Image Format