

X64™-AN Quad



Key Features

- Image time stamp for accurate object tracking of each input channel
- Concurrent acquisition from up to four independent format cameras
- High-speed image transfers at up to 528MB/s
- PCI-X 66MHz compatible
- Supports Windows® Vista® & XP®
- RoHS Compliant

64-bit multi-channel analog frame grabber

The X64-AN Quad is a high-performance PCI-X bus compatible frame grabber for progressive scan analog cameras. Driven by the need to integrate vision automation with multiple view inspection, the X64-AN Quad is designed to deliver concurrent image acquisition from multiple independent standard and progressive scan analog cameras.

In addition to high precision 8-bit digitization and independent camera control signals, the Xcelera-AN also offers 4 independent image paths to the host, creating virtually four frame grabbers in one PCIe x1 slot.

The X64-AN Quad has been built within DALSA's Trigger-to-Image Reliability technology framework. High-speed in-line machine vision applications require tight integration between the trigger, strobe, camera exposure and frame grabber acquisition to ensure data integrity. Trigger-to-Image Reliability leverages DALSA's hardware and software innovations to control, monitor, and correct the image acquisition process from the time that an external trigger event occurs to the moment the data is sent to the PCI bus, providing traceability when errors do occur and permitting recovery from them.



X64™-AN Quad

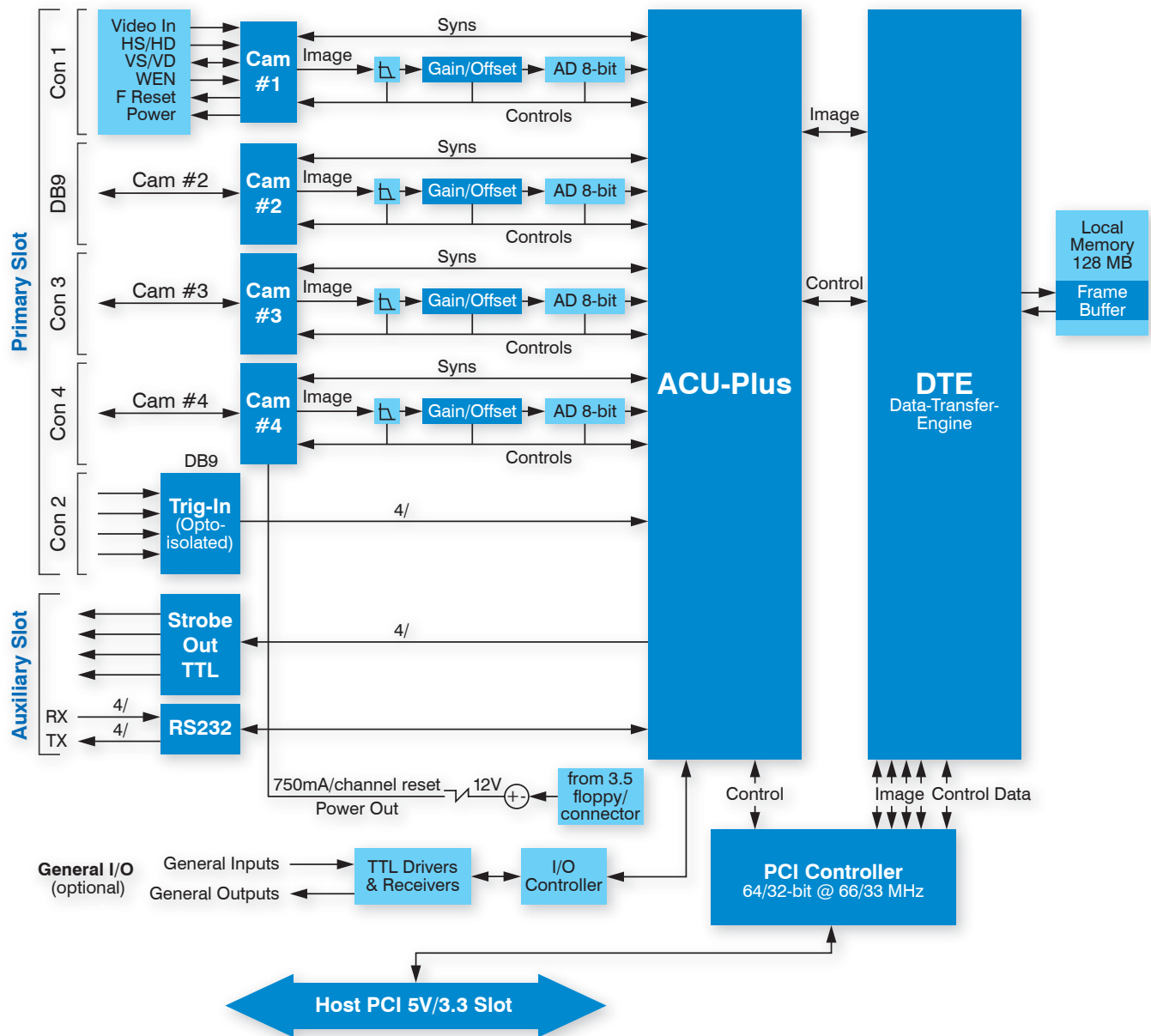

X64-AN Quad—Functional Block Diagram

X64™-AN Quad

Unprecedented Acquisition Control

Successful machine vision applications require consistent and predictable results in demanding operating environments. With all image acquisition functions integrated on a single board and under a single API, the X64-AN Quad ensures highly reliable acquisition control throughout the entire image capture sequence—from the time a trigger is fired to the time an image is available in host memory. Embedded timing logic within the board's Acquisition Control Unit (ACU) provides timing signals to drive HD and VD for each input channel. A dedicated timer/counter for each module also ensures that the acquired images are tracked reliably throughout the data path allowing image data to be readily correlated with physical objects on the production line. Capable of acquiring images at rates up to 50MB/s per input path, the X64-AN Quad makes image acquisition from the new generation of analog cameras more efficient and supports operating modes such as asynchronous reset, E-donpisha, partial scan, and WEN.

Improved Anti-Aliasing Filter

For improved image quality and accuracy, the X64-AN Quad offers an optional fifth order Butterworth anti-aliasing filter to remove unwanted noise from the video signal; separate gain and offset controls for each video input span the entire 0.4 to 1.2V range in steps of 780 μ V. These precise and flexible controls give operators the ability to adapt input video signals to deliver digitized images that are highly linear and have low jitter noise.

Camera Support

The X64-AN Quad performs acquisitions from up to four independent format analog cameras with a comprehensive suite of independent control signals such as master mode synchronization, WEN, frame reset, trigger, and strobe outputs. The X64-AN Quad comes bundled with CamExpert™ a proprietary camera configuration utility specifically designed to leverage the power of DALSA's image acquisition boards. This Windows-based utility provides an interactive environment within which to create a new, or modify an existing, configuration file for both standard and progressive scan cameras.

Visual Status LED

The X64-AN Quad features visual status LEDs to simplify system setup and diagnostics. A status indicator LED provides visual feedback once the camera connection is made and properly synchronized. These visual indicators greatly facilitate the diagnostic process by allowing developers to instantly recognize if cabling has been correctly set up.

Optimized Data Transfer

Delivering fast and secure data transfer with zero CPU usage, the Data Transfer Engine (DTE) features a high-speed memory interface, multiple independent Direct Memory Access (DMA), and onboard tap descriptors, the DTE's powerful architecture delivers robust performance for critical machine vision tasks. The DMAs allow the DTE to transfer images from the ACU to local frame buffer memory, or transfer the same image to

multiple addresses in the host memory. The ACU and DTE use the onboard 128MB memory to perform these operations concurrently, yet at different rates, yielding optimal utilization of system bandwidth. Conventional PCI bus transfers, utilizing scatter-gather techniques, rely on the CPU to load the host frame buffer destination memory addresses during live acquisition, which increases the load on the CPU and slows image-processing tasks. The DTE offloads this task by automatically capturing and storing the destination frame buffer addresses from the host memory. In addition, it performs autonomous and robust image transfers in non-real-time operating systems, such as Windows XP, Windows 2000.

General Purpose I/Os

An optional module offers opto-coupled inputs and outputs for demanding industrial environments. These interrupt-driven, general-purpose input and output controls allow X64-AN Quad boards to react to external inputs more rapidly and predictably increasing the quality of acquired images.

External Event Synchronization

To synchronize image captures with external events the X64-AN Quad features an optically isolated trigger input and a strobe control signal for each input channel. The signals can be programmed as active high or active low, edge or level based and can be controlled independently.

Serial Communication Ports

The X64-AN Quad features four independent onboard RS-232C ports that provide integrated support for camera control and setup for machine vision applications. PC-independent in nature, these communication ports can easily be used with off-the-shelf communication utilities such as Windows-based HyperTerminal.

Software Support

The X64-AN Quad is fully supported by DALSA's Sopera™ Essential vision software. Sopera Essential is a suite of image acquisition and processing libraries, tools and utilities. Sopera Essential offers a powerful camera configuration utility called CamExpert™ and image processing library evaluation tool, Sopera Architect. In addition to more than 300 image processing functions, Sopera Essential offers a selection of image processing tools for machine vision including pattern finding (area and edge based techniques), OCR, barcode, calibration and blob analysis. Fully supported by DALSA's Trigger-to-Image Reliability framework, applications based on the X64-AN Quad products deliver robust, reliable and cost effective solutions.

In addition, Sopera Essential applications can be developed using C/C++, C# and Visual Basic using Microsoft® Visual Studio® 6.0 and higher on Windows XP or Vista 32-bit platforms.

X64™-AN Quad

Specifications*

Function	Description	Function	Description
Board	Full length 64-bit PCI-X 66MHz compatible Supports 5V and 3.3V slots RoHS Compliant	Power	Output Power-on-reset fused +12V DC output at 750 mA(max) for each input channel
Acquisition	Concurrent image acquisition from four independent interlaced or progressive scan analog cameras Single slot solution supports acquisition rates up to 50MHz in 8-bit/pixel mode Horizontal Size (min/max): 32 pixels to 4096 pixels in 1 pixel/step Vertical Size: 1 to 16384 lines in 1 line/step Interfaces to monochrome standard or custom format cameras VBS 1 VPP, 75 ohms terminated Video 0.714 VPP, 75 ohms terminated Partial scan mode	Software	Microsoft Windows Vista, XP and 2000 compliant Full support of DALSA's Sapera programming package Microsoft Visual Studio 6.0 and .NET compatible C/C++ DLLs and ActiveX controls
Synchronization	Supports composite video and separate horizontal and vertical sync input Horizontal/Vertical Drive output, LV TTL and TTL compatible Frame reset and WEN inputs for each channel	System Requirements	PCI-X compliant system and 64MB system memory
Onboard memory Pixel Formats Transfers	128MB Onboard frame buffer memory Monochrome 8-bit/pixel Real-time transfers to system memory: PCI-32 bus: 32 bits @ 33MHz PCI-64 bus: 64 bits @ 66MHz PCI-X bus: 64 bits @ 66MHz	Dimensions	12.25" (31cm) Length x 4.125" (10.5cm) Height
Pixel jitter	Robust error tracking, reporting and recovery	Temperature	0° C (32° F) to 55° C (131° F) Relative Humidity: up to 95% (non-condensing)
Look-up tables	One 256 x 8-bit look-up table per channel	Markings	FCC—class A Approved CE—class B Approved
Noise and Pixel Jitter	+/- 1 LSB with +/- 1.5ns jitter		
Controls	Independent gain/offset control for each input channel from 0.4V to 1.2V 780µV/step Anti-aliasing filter: 12.87MHz, 5th order Butterworth Comprehensive event notification includes end/start-of-field/frame/transfer 4 independent opto-isolated trigger inputs; programmable as active high or low (edge or level trigger) 4 strobes TTL outputs PC independent RS232 serial communication ports provide seamless interface to MS Windows applications		
XIO Module² (optional)	General purpose IO module supports: 8 inputs and 8 TTL outputs Inputs support TTL and 24V operations TTL outputs support PNP and NPN operations		

* Specifications last updated 10/08

¹ Available Q4 2008

² Requires additional free slot

www.dalsa.com

Americas

Boston, USA
Tel: +1 978-670-2000
sales.americas@dalsa.com

Europe

Munich, Germany
Tel: +49 8142-46770
sales.europe@dalsa.com

Asia Pacific

Tokyo, Japan
+81 3-5960-6353
sales.asia@dalsa.com

DALSA is an international leader in digital imaging and semiconductors and has its corporate offices in Waterloo, Ontario, Canada.

All trademarks are registered by their respective companies. DALSA reserves the right to make changes at any time without notice. © DALSA 2008. x64_an_quad_100608

